



International Journal of Advanced Research in Electrical, Electronics and Instrumentation Engineering

(A High Impact Factor, Monthly, Peer Reviewed Journal)

Website: www.ijareeie.com

Vol. 8, Issue 2, February 2019

A Survey on Challenges and Opportunities of Waste Management in IOT Enabled Smart Cities

Pournima Abhishek Kamble, Vinod Motiram Rathod, Sujata Shankar Gawade

Professor, Department of Computer Technology, Bharati Vidyapeeth Institute of Technology, New Mumbai, India

Professor, Department of Computer Technology, Bharati Vidyapeeth Institute of Technology, New Mumbai, India

Professor, Department of Computer Technology, Bharati Vidyapeeth Institute of Technology, New Mumbai, India

ABSTRACT: As the population is increasing day by day, the environment should be clean and hygienic. In most of the cities the overflows garbage bins are creating an unhygienic environment. This will further lead to arise of different types of unnamed diseases. This will degrade the standard of living. To overcome these situations an efficient smart garbage management method has to be developed. A major part of the world today has a throwaway culture, producing huge amounts of solid wastes. Advancements in environmental measurement techniques clearly indicate that demand on the earth's resources is not sustainable and should be addressed immediately. Due to rapid population growth, disorganization of city governments, a lack of public awareness and limited funding for programs, garbage management is becoming a global problem. Due to the lack of care and attention by the authorities the garbage bins are mostly seem to be overflowing. This project involves garbage management ideas contains three IR sensors connected to the garbage tank at three positions. If IR1 detect the garbage at 1st level then the motor1 will push the garbage into forward direction in the tank. If IR2 detect the garbage at 2nd level then the motor2 will push the garbage into downward direction in the tank. If IR3 sensor detects 3rd level then we get the text message as garbage tank is full on main control unit.

KEYWORDS: Environment, Garbage, IR Sensor.

I. INTRODUCTION

The process of making things automatic is being abused in all the real fields of life. Making things automatic reduces load on the human. The cost and exertion utilized as a part of physically controlled items is significantly higher than the computerized frameworks. Considering the reality, that the issue of proficient waste administration is one of the significant issues of the advanced circumstances, there is a most extreme need to address this issue. The best possible waste administration framework is must for the sterile society by and large and for world in general. Strong waste which is one of the sources and reasons for ecological contamination has been characterized under Resource Conservation and Recovery Act as any strong, semi-strong fluid or contained vaporous materials disposed of from mechanical, business, mining or rural operations and from group exercises. Strong waste additionally incorporates junk, development flotsam and jetsam, business won't, and ooze from water or waste treatment plants or air contamination, control offices and other disposed of materials.

So as to shield human wellbeing and nature from the potential dangers of postponed squander transfer and ecological contamination a methodically regulated and controlled treatment of these squanders is must. The sort of squanders which constitute natural contamination and which this work underlines on is residential decline comprising of degradable nourishment squander s, leaves, dead creatures and non-degradable ones, for example, plastics, bottles, nylon, therapeutic and doctor's facility squanders, produced in family units, doctor's facilities, businesses and business focuses.



International Journal of Advanced Research in Electrical, Electronics and Instrumentation Engineering

(A High Impact Factor, Monthly, Peer Reviewed Journal)

Website: www.ijareeie.com

Vol. 8, Issue 2, February 2019

II. OBJECTIVES

The objective of the proposed system is given below.

- To proposed a system which can accurately manage the garbage from the city.

III. LITERATURE SURVEY

In literature, the problem and the previous techniques of smart cities detection is described.

Swachh Bharat Abhiyaan is a national battle started by the Government of India, which covers 4,041 urban areas and towns, to clean the lanes, streets and foundation of the nation. The primary proverb of the mission is to cover all the rustic and urban ranges of the nation. With multiplication of Web of Things (IoT) gadgets, for example, Smartphone sensors, this paper portrays the powerful dry what's more, wet earth gathering utilizing Embedded System. The principle witticism of the application is gathering of dry and wet waste independently which is set in a transport line on which the dry waste gathered clean containers are put left side and wet waste gathered receptacles on right side. The framework will get the contribution through the tidy gathering individual through switches and sends flag to the Micro controller unit utilizing RF innovation and that influences the H-to scaffold to turn transport line. At the point when the belt begins pivoting clockwise the clean containers cover is naturally shut, all the while the waste is dumped into the underground waste compartment put at the ground floor. Here IoT module is utilized to control and screen the waste and the data will be sent to the specific association and the normal man. The portable application demonstrates the gathering of waste and the specific date and entry time of the vehicle [1].

Brilliant Waste Management utilizing Internet of Things: A Survey At introduce strong waste administration is a noteworthy worry in the metropolitan urban areas of the creating what's more, created nations. As the populace is developing, the waste is likewise expanding. This colossal unmanaged gathering of waste is dirtying the earth, ruining the excellence of the territory and furthermore prompting the wellbeing danger. In this period of Internet, IOT (Internet of Things) can be utilized successfully to deal with this strong waste. In this paper, we have talked about the meaning of Internet of Things and its components, testing and prototyping apparatus cooja test system lastly the investigation of different writings accessible on savvy squander administration framework utilizing IOT [2]. This paper proposes a savvy ready framework for refuse freedom by giving a ready flag to the civil web server for moment cleaning of dustbin with appropriate check in view of level of waste filling. This process is helped by the ultrasonic sensor which is interfaced with Arduino UNO to check the level of refuse filled in the dustbin and sends the caution to the metropolitan web server once if waste is filled. In the wake of cleaning the dustbin, the driver affirms the undertaking of purging the waste with the guide of RFID Tag. RFID is a figuring innovation that is utilized for confirmation process and likewise, it likewise improves the savvy junk ready framework by giving programmed recognizable proof of waste filled in the dustbin and sends the status of tidy up to the server avowing that the work is finished. The entire procedure is maintained by an installed module incorporated with RF ID and IOT Facilitation. The constant status of how squander gathering is being done could be observed and followed up by the district expert with the guide of this framework. Notwithstanding this the important therapeutic /interchange measures could be adjusted. An Android application is produced and connected to a web server to insinuate the alarms from the microcontroller to the urban office and to play out the remote observing of the cleaning procedure, done by the laborers, in this manner decreasing the manual procedure of observing and confirmation. The notices are sent to the Android application utilizing Wi-Fi module [3]. A Survey on Smart Garbage Management in Cities utilizing IoT As the populace is expanding step by step, the earth ought to be perfect and clean. In most of the urban areas the flooded waste containers are making an unhygienic domain. This will further prompt emerge of various sorts of anonymous maladies. This will corrupt the way of life. To defeat these circumstances an effective shrewd refuse administration strategy must be created. As the extent of IoT is creating step by step successful techniques can be discovered effortlessly. Different outlines were proposed and have favorable circumstances and additionally impediments. This paper is an overview based on Smart Garbage Management in Cities utilizing IoT. This study includes different shrewd trash administration thoughts that can be effectively implemented [4].

A Smart Waste Management and Monitoring System utilizing Automatic Unloading Robot In our city, dustbins set at open spots are overflowing. It makes unhygienic conditions for the individuals. Likewise it makes offensiveness to that



International Journal of Advanced Research in Electrical, Electronics and Instrumentation Engineering

(A High Impact Factor, Monthly, Peer Reviewed Journal)

Website: www.ijareeie.com

Vol. 8, Issue 2, February 2019

place. In the meantime awful stench is additionally spread. These days, there are number of systems which are intentionally utilized are being develop for well administration of trash or strong waste. We will actualize an undertaking called A Smart Waste Management also, Monitoring System with programmed Unloading Robot to maintain a strategic distance from circumstances of this sort. To give a short depiction, at general society puts, the sensors are set in the regular refuse canisters. At the point when the refuse achieves the level of the sensor, at that point that sign will be given to PIC microcontroller. Robot used to gather the losses in the wake of achieving high wastage level. To move the robot from waste region and empty the wastage by Using DC Motor. The waste filling level and air contamination level is sent as message through GSM modem interface to the microcontroller. The result of this strategy is effective and insightful and can be utilized to mechanize any strong waste canister administration process [5]. Idea, Design and Implementation of Automatic Waste Management System One of the principle worries with our condition has been strong waste administration which what's more to irritating adjust of the earth additionally effectively affects the strength of the society. The discovery, checking and administration of squanders are one of the essential issues of the present period. The conventional method for physically checking the losses in squander canisters is a complex, awkward process and uses more human exertion, time and cost which aren't good with the present day innovations in any capacity. This paper proposes a propelled technique in which squander administration is robotized. Radio recurrence recognizable proof (RFID) is a standout amongst the most encouraging and expected innovations as of late. The framework makes utilization of radio recurrence (RF) labels and web bolster. This work introduced here unquestionably gives a novel approach in taking care of and arranging off the everyday strong squanders in an effective and simple way. The framework comprises of four principle subsystems to be specific Smart Trash System (STS), Local Base Station (LBS), Smart Vehicle System (SVS) and Smart Monitoring and Controlling Hut (SMCH). The proposed framework would have the capacity to computerize the strong waste checking procedure and administration of the general accumulation process. The advances that would be utilized as a part of the proposed framework are sufficient to guarantee the down to earth and culminate strong waste gathering process checking and administration for green environment [6]. In many spots, it can be seen that the Municipal junk receptacles are flooding and they are definitely not cleaned at appropriate time. Because of which the results are extreme. It incorporates flood of rubbish which brings about land contamination, spread of sicknesses. It likewise makes unhygienic conditions for individuals and offensiveness to that place. There ought to be a framework that can screen the container and can give the data of filling of the receptacle to the region utilizing remote sensor organize so that the canister can be cleaned on time and the earth can be defended. This paper introduces the Brilliant waste administration framework that recognizes completion of the canister utilizing a remote sensor organize (WSN) and installed Linux board and educate the approved individual for the cleaning of the canister. The framework gives a web interface to the cleaning expert with the goal that they can screen and clean the trash canister. In this paper, Raspberry Pi is utilized as an inserted Linux board which is composed in view of the arm 11 microcontroller designs. Inserted Linux board makes the correspondence with all circulated sensor hubs set in the tried zone through ZigBee convention and itself go about as a planned hub in the remote sensor organize. The objective of facilitator hub is to gather the parameters like level of the container and scent remotely. Every sensor hub comprises of level sensor furthermore, gas sensors and one ZigBee RF radio wire gadget for correspondence with the organizer hub. Raspberry Pi stores gathered information in the database and investigations the put away information. The board has an Ethernet interface and runs the basic information web server. Thus organizer gathers the information over ZigBee remote correspondence convention and enable client to screen the information from a web program. Cleaning expert can gather the waste on time [7].

In the present day situation, ordinarily we see that the Garbage canisters or Dust containers set at open puts in the urban areas are flooding because of increment in the waste each day. It makes unhygienic condition for the general population and terrible scent around the surroundings this leads in spreading some lethal maladies and human disease; to stay away from such a circumstance we want to plan Garbage Monitoring Framework utilizing IoT. In this proposed framework there are different dustbins situated all through the city or, then again Campus, these dustbins are furnished with minimal effort gadget which helps in following the level of trash receptacles and an one of a kind ID will be accommodated each dustbin so it is anything but difficult to distinguish which refuse container is full. At the point when the level achieves edge confine, the gadget will transmit the level along with the one of a kind ID gave. These subtle elements can be gotten to by the worry experts from their put with the assistance of Internet and a prompt activity can be made to clean the dustbins [8]. In the present day circumstance, regularly we see that the refuse canisters or Dust compartment are put at open places in the urban groups are flooding a direct result of addition in the waste

International Journal of Advanced Research in Electrical, Electronics and Instrumentation Engineering

(A High Impact Factor, Monthly, Peer Reviewed Journal)

Website: www.ijareeie.com

Vol. 8, Issue 2, February 2019

every day. It makes unhygienic condition for the all inclusive community and makes terrible stench around the surroundings this leads in spreading some risky infections and human malady, to avoid such a situation we are aiming to design "IoT Based Waste Management for Smart Cities". In this proposed System there are distinctive dustbins arranged all through the city or the Campus, these dustbins are outfitted with negligible exertion embedded contraption which helps in following the level of the waste canisters and a unique ID will be suited every dustbin in the city so it is definitely not hard to perceive which garbage container is full. Exactly when the level accomplishes beyond what many would consider possible, the device will transmit the level nearby the extraordinary ID gave. These unobtrusive components can be gotten to by the stress pros from their place with the help of Internet and a snappy movement can be made to clean the dustbins [9]. The Main point of this paper is to build up an insight canister which can screen squander through sensors and gives the data in definite which are associated with web. At first every one of the sensors from various area are associated through Internet in each area sensors will quantify and figure the waste and data will be sent to the server. At Server it will Process the data and sent it to the worry Authorities to make essential move. By This approach we can get data of receptacle by utilizing an android application also [10].

IV. SYSTEM DESIGN

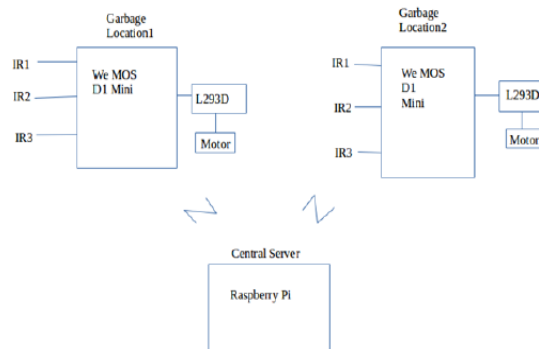

Fig1: Diagram of planned design

The main focus of this system is to manage garbage in cities. This system uses infrared sensor for detecting level of garbage in garbage tank. After detecting level of garbage in garbage tank motor will automatically on to manage garbage in tank. In the proposed system we are monitoring level garbage present at two locations. Three sensors detect the level of garbage dumped on the dustbin. If IR1 detect the garbage at 1st level then the motor1 will push the garbage into forward direction in the tank. If IR2 detect the garbage at 2nd level then the motor2 will push the garbage into downward direction in the tank. Similarly IR3 detect the 3rd level garbage i.e. when tank will become full. If garbage tank is totally full then the information "tank is full" is send to the main central unit (Raspberry pi) and display on the webpage. On this information sudden action took by garbage management committee.

International Journal of Advanced Research in Electrical, Electronics and Instrumentation Engineering

(A High Impact Factor, Monthly, Peer Reviewed Journal)

Website: www.ijareeie.com

Vol. 8, Issue 2, February 2019

V. EXPERIMENTAL RESULTS

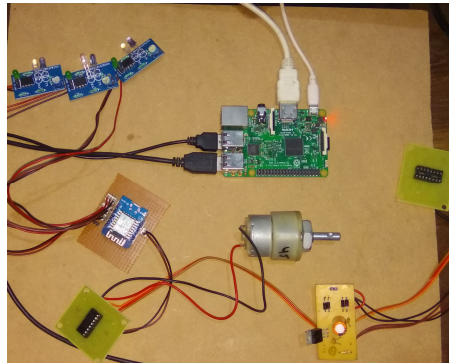

Fig2:- hardware of proposed system

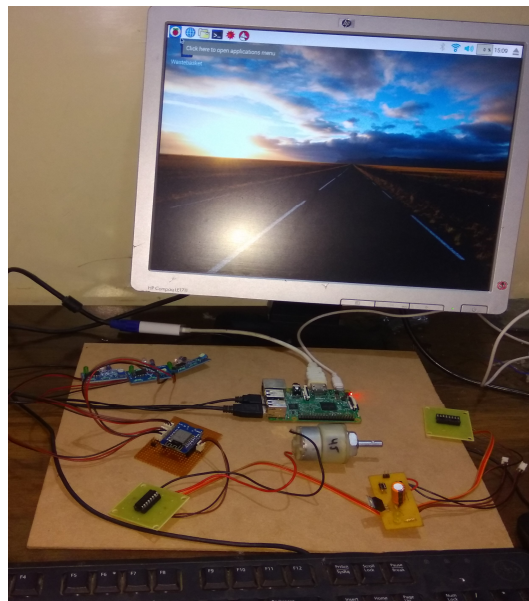

Fig2:- Proposed system.

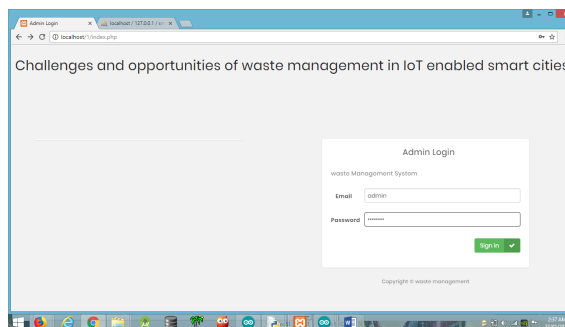

Fig3:- webpage showing admin login



International Journal of Advanced Research in Electrical, Electronics and Instrumentation Engineering

(A High Impact Factor, Monthly, Peer Reviewed Journal)

Website: www.ijareeie.com

Vol. 8, Issue 2, February 2019

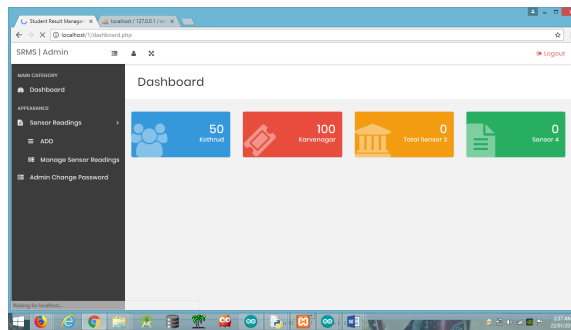

Fig4:- webpage displays condition of dustbin

Above result shows the interfacing of different hardware like IR sensors, motor, Wemos d1 mini, mouse and keyboard with Raspberry pi and the OS of Raspberry is, as shown in fig., running on the monitor.

VI. CONCLUSION

A garbage management system is a step forward to make the manual collection and detection of wastes automated in nature. The currently employing method in which concerned municipal employee has to look for the filled waste bins manually across different spots in an area/street for checking regularly whether the waste bin is filled or not, which is complex and time consuming process. This automation of waste also reduces the human effort and consequently the cost of the whole process. Using IOT one can track garbage/bin location, load, missing/stolen bins, the level of the waste in garbage bins and to suggest the shortest route for rapid collection of solid waste without or minimum human intervention.

REFERENCES

- [1] Bharadwaj B, M Kumudha, Gowri Chandra N, Chaitra G, "AUTOMATION OF SMART WASTE MANAGEMENT USING IoT TOSUPPORT "SWACHH BHARAT ABHIYAN" – A PRACTICAL APPROACH", IEEE, 2017.
- [2] Pallavi K N, Dr. Ravi Kumar V, Chaitra B M, "Smart Waste Management using Internet of Things:A Survey", International conference on I-SMAC (IoT in Social, Mobile, Analytics and Cloud), I-SMAC 2017.
- [3] Dr.N.SATHISH KUMAR, B.VIJAYALAKSHMI, R. JENIFER PRARTHANA, A .SHANKAR, "IOT Based Smart Garbage alert system using Arduino UNO",IEEE, 2016.
- [4] Ruhin Mary Saji, Drishya Gopakumar, Harish Kumar S, K N Mohammed Sayed, Lakshmi s, "A Survey on Smart Garbage Management in Cities using IoT", International Journal Of Engineering And Computer Science ISSN: 2319-7242, Volume 5 Issue 11 Nov. 2016, Page No. 18749-18754.
- [5] Nithya.L, Mahesh.M, "A Smart Waste Management and Monitoring System using Automatic Unloading Robot", International Journal of Innovative Research in Computer and Communication Engineering (An ISO 3297: 2007 Certified Organization) Website: www.ijirccce.com, Vol. 4, Issue 12, December 2016.
- [6] Adil Bashir, Shoaib Amin Banday, Ab. Rouf Khan, Mohammad Shafi, "Concept, Design and Implementation of Automatic Waste Management System", International Journal on Recent and Innovation Trends in Computing and Communication, ISSN 2321 – 8169, 604 – 609, Volume: 1 Issue: 7, JULY 2013.
- [7] Kusum Lata, Shri S. K. Singh, "IOT BASED SMART WASTE MANAGEMENT SYSTEM USING WIRELESS SENSOR NETWORK AND EMBEDDED LINUX BOARD", International Journal of Current Trends in Engineering & Research (IJCTER) e-ISSN 2455–1392 Volume 2 Issue 7, July 2016 pp. 210 – 214 Scientific Journal Impact Factor : 3.468 <http://www.ijcter.com>.
- [8] Harshita A. Gawad, SurajKadam, Dona Jain, Nirav Patel, "An IOT based Dynamic Garbage Level Monitoring System using Raspberry-pi", Harshita A. Gawad. Int. Journal of Engineering Research and Application www.ijera.com ISSN : 2248-9622, Vol. 7, Issue 7, (Part -7) July 2017, pp.30-34.
- [9] Parkash , Prabu V, "IoT Based Waste Management for Smart City", International Journal of Innovative Research in Computer and Communication Engineering (An ISO 3297: 2007 Certified Organization) Vol. 4, Issue 2, February 2016.
- [10] Harshita Chugh, Dushyant singh, Shahensha shaik, Ashwani Singla, "IOT Based Smart Bin", International Research Journal of Engineering and Technology (IRJET) e-ISSN: 2395-0056 Volume: 04 Issue: 09 | Sep -2017 www.irjet.net p-ISSN: 2395-0072